



US00D917413S

(12) **United States Design Patent**  
**DeMaio**

(10) **Patent No.:** **US D917,413 S**

(45) **Date of Patent:** **\*\* Apr. 27, 2021**

- (54) **VOICE ASSISTED DIGITAL INTERFACE DEVICE**
- (71) Applicant: **PHINGE CORPORATION**, Sparks, NV (US)
- (72) Inventor: **Robert Charles DeMaio**, Sparks, NV (US)
- (\*\*) Term: **15 Years**
- (21) Appl. No.: **29/702,121**
- (22) Filed: **Aug. 16, 2019**
- (51) **LOC (13) CL.** ..... **14-03**
- (52) **U.S. CL.**  
USPC ..... **D14/171; D14/496; D14/168; D10/2; D10/22**
- (58) **Field of Classification Search**  
USPC ..... D14/356, 357, 358, 216, 240, 242, 299, D14/125, 140, 140.1, 155, 168, 188, 195, D14/300, 302, 314, 348, 351, 388, 496, D14/142, 203.1, 204, 228, 230; D10/2, D10/3, 4, 5, 21, 22, 104.1, 106.1, 106.3, D10/106.5, 106.6, 116.1, 6.9, 121; D26/110, 106; D15/199; D13/162, 168  
CPC ... H04W 88/08; H04W 88/085; H04W 88/00; H04W 88/005; H04W 88/02; H04W 88/12; H04W 88/14; H04W 88/16; H04W 88/18; H04W 4/00; H04M 2250/12; H04B 1/38; G06F 3/16; G06F 3/167  
See application file for complete search history.

D162,829 S *	4/1951	Hoeflich .....	D14/168
D165,132 S *	11/1951	Bruce .....	D10/22
D172,266 S *	5/1954	Bruce .....	D10/22
D174,986 S *	6/1955	Fletcher .....	D10/22
D187,608 S *	4/1960	Merrigan .....	D10/22
D189,303 S *	11/1960	Florian .....	D10/22
3,033,945 A *	5/1962	Villchur .....	H04R 9/06 381/413
D215,466 S *	10/1969	Jones, Jr. ....	D10/22
D219,648 S *	1/1971	Weaver .....	D25/11
D239,958 S *	5/1976	Robert .....	D99/35
D253,522 S *	11/1979	Rutenberg .....	D10/22
D272,921 S *	3/1984	Kim .....	D14/417
D286,399 S *	10/1986	Willy .....	D14/222
D302,010 S *	7/1989	McLaughlin .....	D14/417
D323,327 S *	1/1992	Davidson .....	D14/219
D349,976 S *	8/1994	Connell .....	D28/76
D357,234 S *	4/1995	Yoshihara .....	D14/358

(Continued)

*Primary Examiner* — Marie D. Fast Horse  
(74) *Attorney, Agent, or Firm* — Tatonetti IP

(57) **CLAIM**

The ornamental design for a voice assisted digital interface device, as shown and described.

**DESCRIPTION**

FIG. 1 is a perspective view of a voice assisted digital interface device, showing my new design; FIG. 2 is a front elevation view thereof; FIG. 3 is a rear elevation view thereof; FIG. 4 is a left side elevation view thereof; FIG. 5 is a right side elevation view thereof; FIG. 6 is a top view thereof; and, FIG. 7 is a bottom view thereof.

The broken dot-dash lines showing the time depict an environmental state of use and form no part of the claimed design; while all other broken lines depict portions of the voice assisted digital interface device that form no part of the claimed design.

**1 Claim, 7 Drawing Sheets**

- (56) **References Cited**  
U.S. PATENT DOCUMENTS  
D103,791 S \* 3/1937 Rusch ..... D10/22  
D110,246 S \* 6/1938 Guild ..... D10/22  
D130,316 S \* 11/1941 Schulman ..... D10/22  
D145,576 S \* 9/1946 Hallward ..... D10/22  
D158,929 S \* 6/1950 Bruce ..... D10/22  
D160,434 S \* 10/1950 Schlenker ..... D10/22

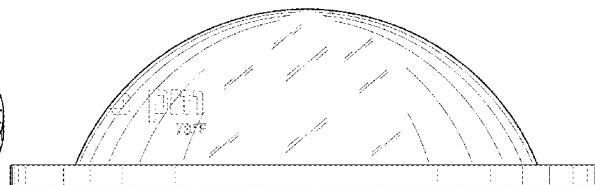
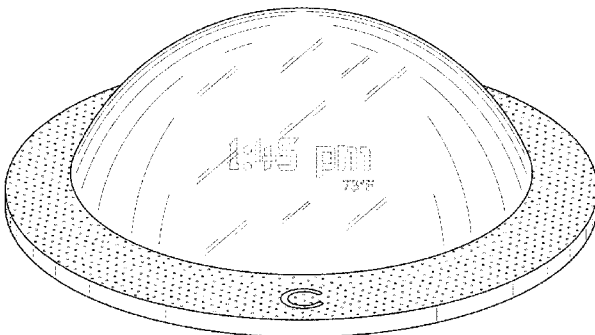

(56)

References Cited

U.S. PATENT DOCUMENTS

D368,721 S \* 4/1996 Howell ..... D14/240  
 D377,485 S \* 1/1997 Kaneko ..... D14/417  
 D382,261 S \* 8/1997 Kaneko ..... D14/417  
 D392,900 S \* 3/1998 Shields ..... D10/22  
 D396,852 S \* 8/1998 Chao ..... D14/358  
 D397,374 S \* 8/1998 Brooks ..... D14/417  
 D399,499 S \* 10/1998 Kaneko ..... D14/417  
 D434,747 S \* 12/2000 Bird ..... D14/150  
 D444,777 S \* 7/2001 Bird ..... D14/150  
 D445,675 S \* 7/2001 Richardson ..... D28/8.1  
 D446,447 S \* 8/2001 Richardson ..... D28/8.1  
 D452,058 S \* 12/2001 Munroe-Browne ..... D99/5  
 D468,216 S \* 1/2003 Hsu ..... D10/15  
 D475,932 S \* 6/2003 Li ..... D10/12  
 D552,607 S \* 10/2007 Cleland ..... D14/358  
 D575,210 S \* 8/2008 Johannsen ..... D12/192  
 D575,211 S \* 8/2008 Wlotzka ..... D12/192  
 D575,712 S \* 8/2008 Johannsen ..... D12/192  
 D598,898 S \* 8/2009 Davidson ..... D14/215  
 D610,458 S \* 2/2010 Martin ..... D9/504  
 D647,917 S \* 11/2011 Voorhees ..... D14/496

8,188,842 B2 \* 5/2012 Otsuka ..... H01H 19/005  
 340/12.22  
 D711,345 S \* 8/2014 Liu ..... D14/140  
 D729,730 S \* 5/2015 Gillespie-Brown ..... D13/110  
 D735,413 S \* 7/2015 Smith ..... D28/85  
 D738,353 S \* 9/2015 Slaato ..... D14/216  
 D755,162 S \* 5/2016 He ..... D14/216  
 D766,877 S \* 9/2016 Haase ..... D14/215  
 D795,936 S \* 8/2017 Miller ..... D15/199  
 D804,533 S \* 12/2017 Mangum ..... D14/496  
 D808,080 S \* 1/2018 Corey ..... D28/85  
 D811,361 S \* 2/2018 Peng ..... D14/149  
 D825,529 S \* 8/2018 Huang ..... D14/216  
 D832,306 S \* 10/2018 Liao ..... D14/496  
 D850,486 S \* 6/2019 Anderson ..... D14/496  
 D852,229 S \* 6/2019 Akana ..... D14/496  
 D860,257 S \* 9/2019 Akana ..... D14/496  
 D863,356 S \* 10/2019 Akana ..... D14/496  
 D874,008 S \* 1/2020 Kotzer ..... D14/225  
 D883,329 S \* 5/2020 Shi ..... D14/496  
 D891,725 S \* 7/2020 Camarato ..... D99/37  
 D901,747 S \* 11/2020 Lin ..... D26/94  
 D905,316 S \* 12/2020 Bie ..... D26/93

\* cited by examiner

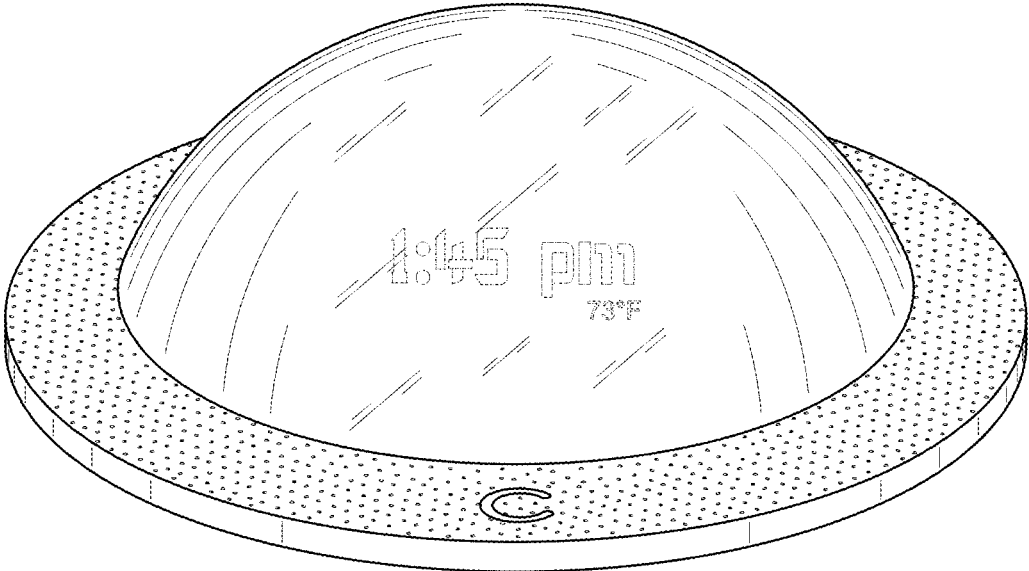

FIG. 1

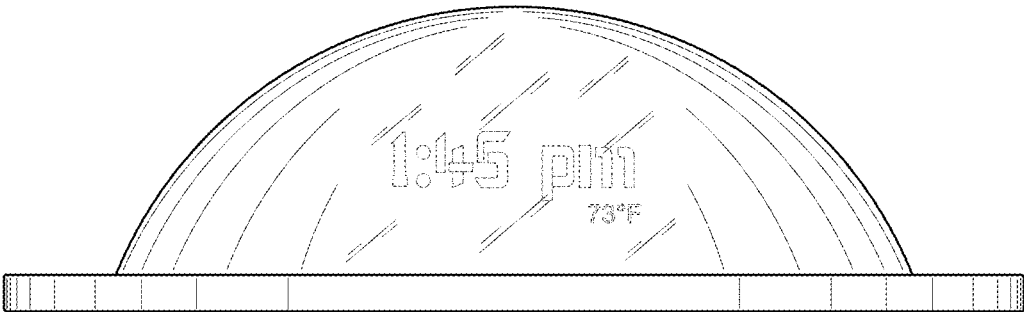

FIG. 2

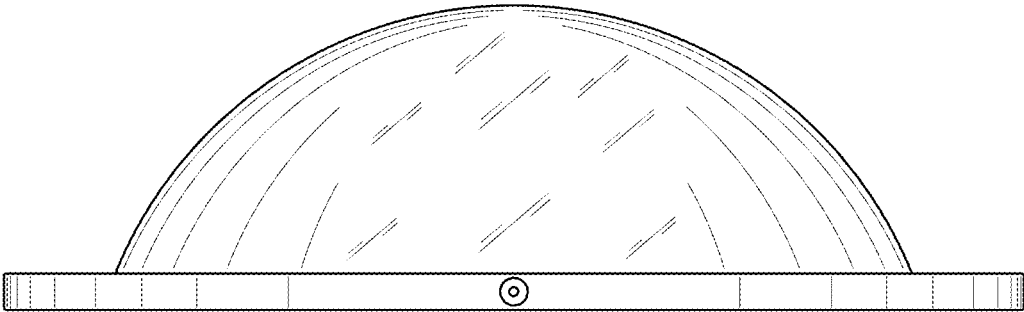

FIG. 3

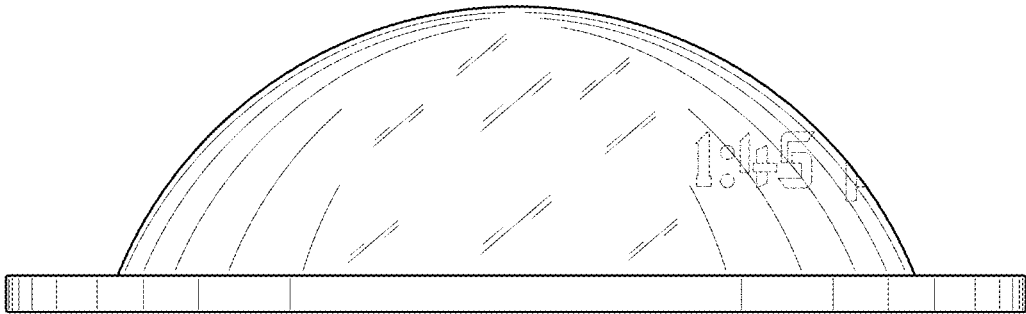

FIG. 4

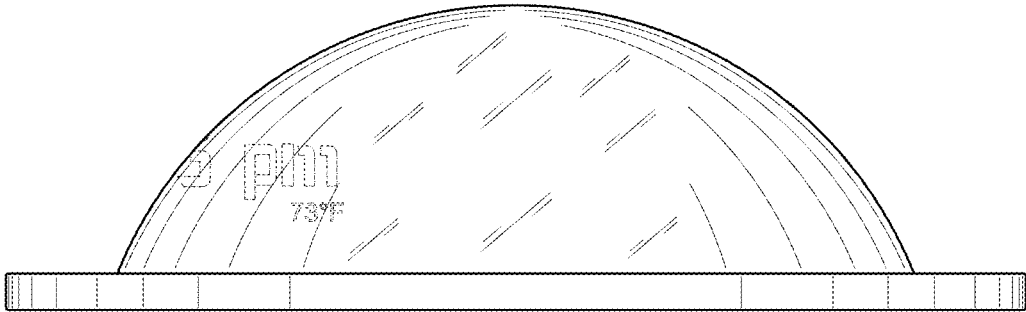

FIG. 5

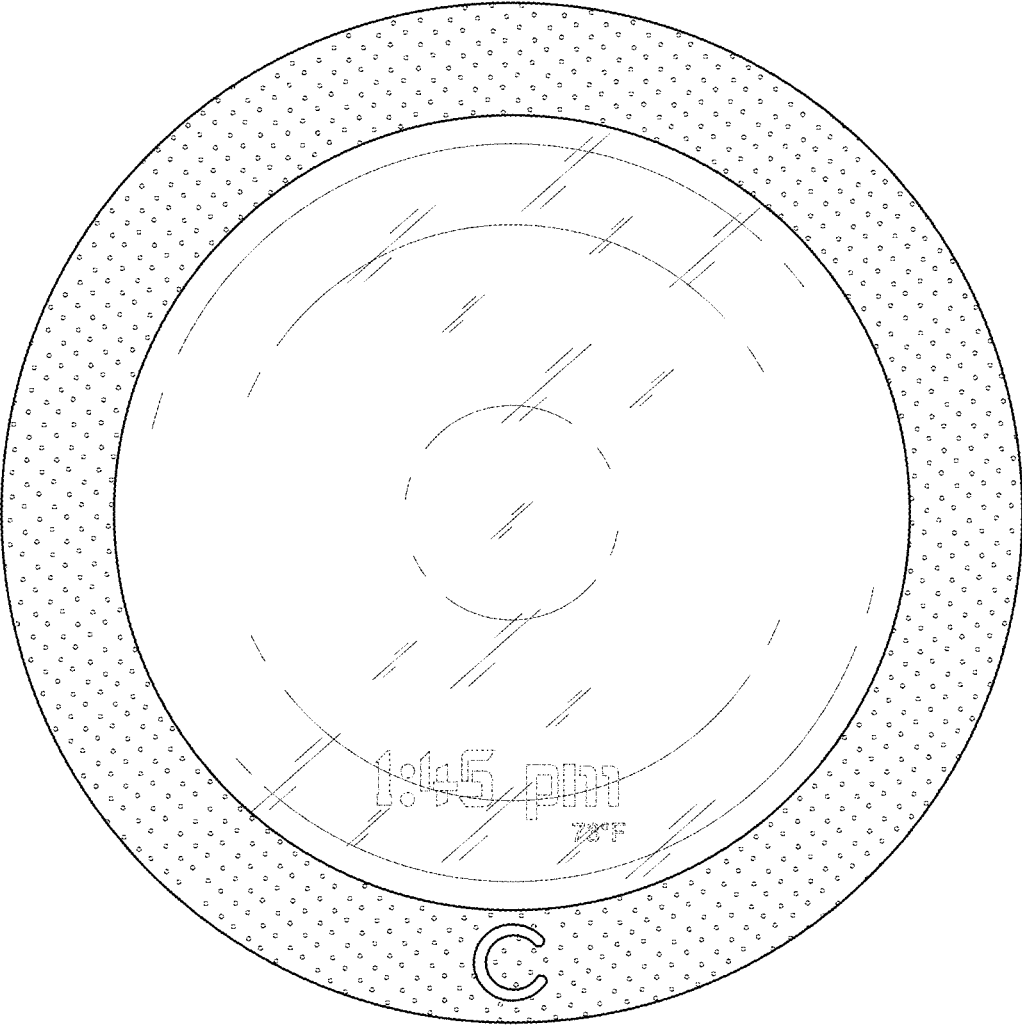

FIG. 6





FIG. 7